



Intelligent Power Systems

Modular Power Distribution System (MPDS) for Packaged Generators

CONNECTION AND POWER DISTRIBUTION FOR PACKAGED GENERATORS

Packaged Generators that contain synchronizing controls and a synchronizing circuit breaker (or switching device) may be applied to create on-site power systems with scalable capacity by aggregating the individual packaged generator output.

To optimize the generator aggregation and provide power distribution points, a Modular Power Distribution System (MPDS) consisting of low voltage switchgear may be applied for cost effective connection, protection, control and isolation capability.

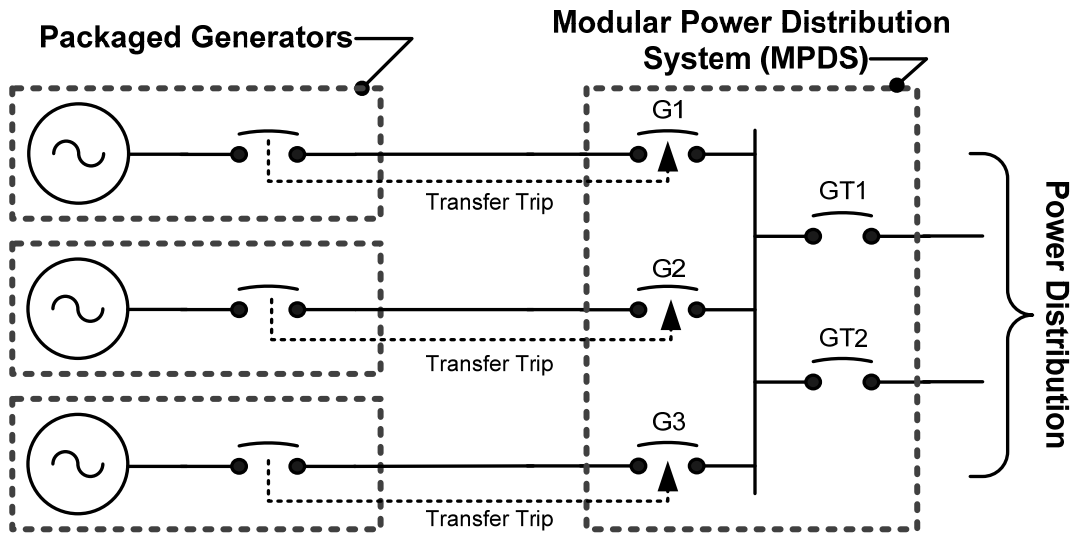

Figure 1: MPDS for 3 Packaged Generators, 2 GT CBs, Single Bus, Fixed CBs

The MPDS may be configured as follows:

- Multiple packaged generator connections
- Multiple power distribution connections
- Fixed, draw out or plug in CBs
- Coordinated protection using LSI, LSIG or LSIA trip units
- Utility-grade protective relays
- Closed transition control of internal/external CBs
- Single, M-T-M or M-T-M-T-M bus topologies
- Shunt trip (transfer trip) capability for the CBs with provision for wiring connection between the Packaged Generators and the MPDS
- Transfer control for multi-bus and/or Utility connected systems
- Bus protection
- Other equipment (ex., meters) as required

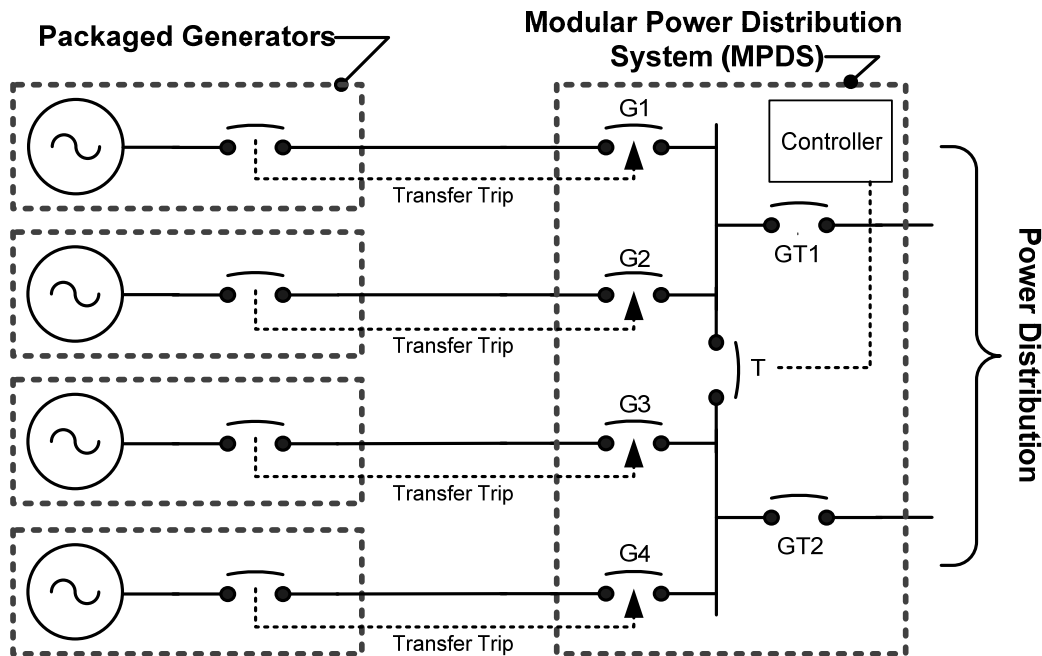

Figure 2: MPDS for 4 Packaged Generators, 2 GT CBs, 1 Bus Tie CB, M-T-M Bus, Fixed CBs Closed Transition Control for T CB

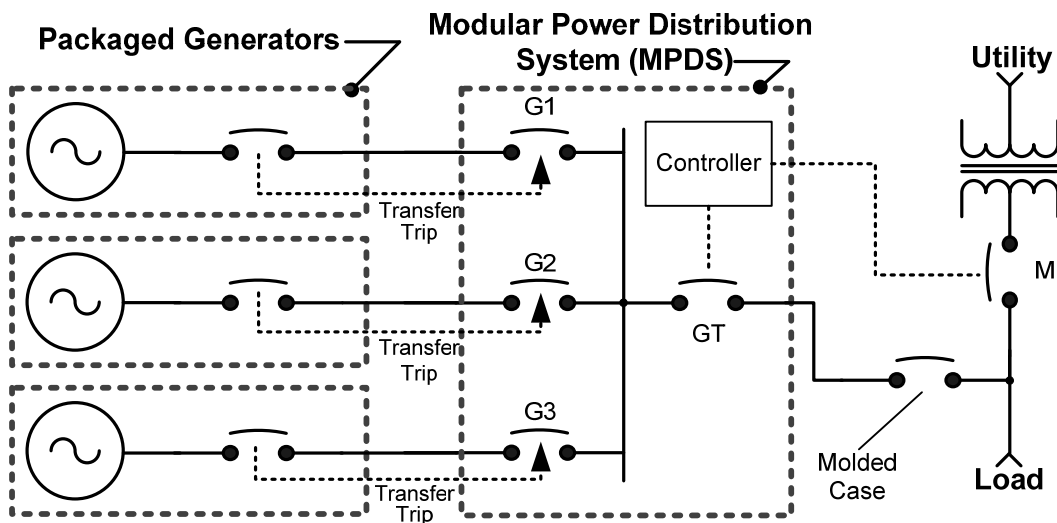

Figure 3: Example 1-Line; MPDS for 3 Packaged Generators, 1 GT CB, Single Bus, Fixed CBs Closed Transition Control of GT and M CBs

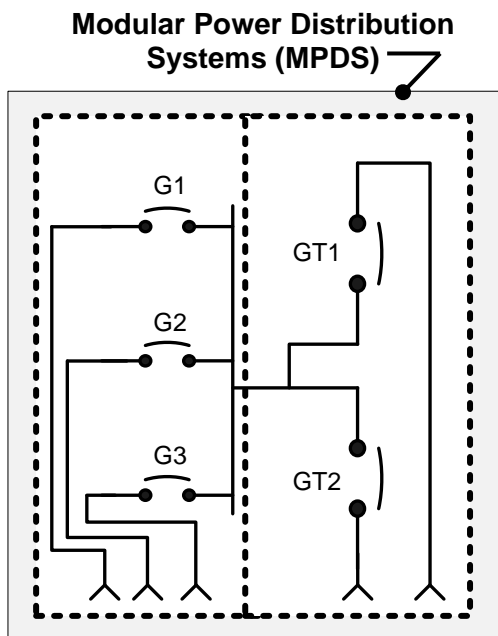

Figure 4
 MPDS for 3 Packaged Generators,
 2 GT CBs, Single Bus, Fixed CBs
 Packaged Generators not shown

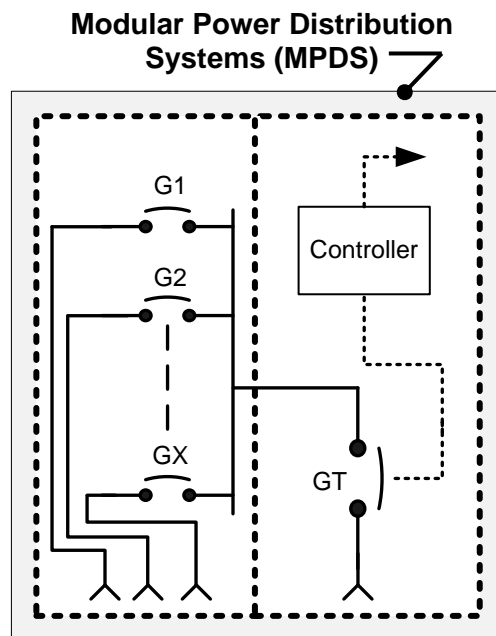

Figure 5
 MPDS for up to 6 Packaged Generators,
 1 GT CB with Closed Transition Control
 (using external CB), Single Bus,
 Fixed CBs,
 Packaged Generators not shown

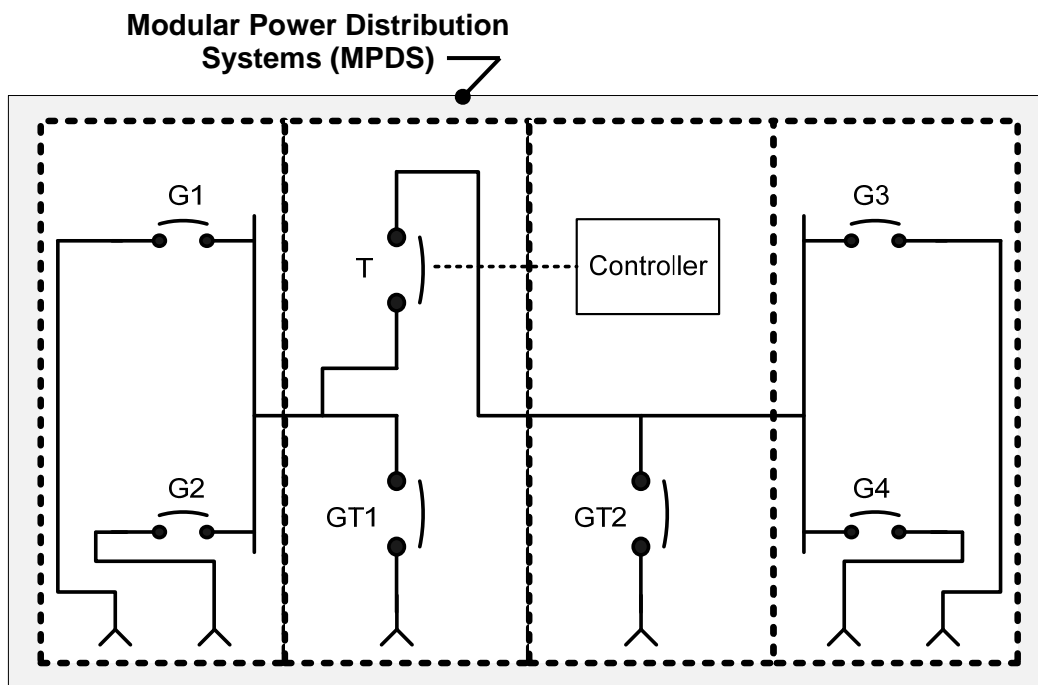

Figure 6: MPDS for 4 Packaged Generators,
 Dual Bus, Fixed CBs, Closed Transition Control of T CB
 Packaged Generators not shown

MPDS Operation (General):

1. Normally all CBs in the MPDS are closed, except for bus tie CBs or MPDS tie CBs interlocked with a Utility connection CBs (if used).
2. Each Packaged Generator starts and syncs using its own control and CB (or switching device).
3. If any Packaged Generator trips due to fault, (not a normal shutdown), a transfer trip is issued to the generator's corresponding GX CB in the MPDS. This isolates the cable between the MPS Generator and the MPDS in case the fault was located in the cable or the Packaged Generator CB.
4. MPDS CBs may employ trip units for selective coordination between the Packaged Generator CBs, the MPDS CBs and the connected power system's CBs.

MPDS Operation (Tie CBs and Utility Connection):

5. Where ties are made between buses within the MPDS, or between the MPDS and a Utility connection CB, if both sources are energized, a closed transition transfer is applied that ensures the CB closure is made synchronously and without outage. See Figures 2 and 6.
6. Where a tie is made between the MPDS and an external Utility connection CB, transfer control is used to provide emergency power to the loads while the Utility is deenergized, and to apply closed transition control when the Utility power returns. See Figures 3 and 5.
7. For peak shaving using parallel operation of the generators with the Utility, the Utility connection can be made to the MPDS with the generators offline, and then each generator will start and sync using its own control and CB or switching device. See Figures 3 and 5.